

# Real-Time Spectrum Analysis Overview

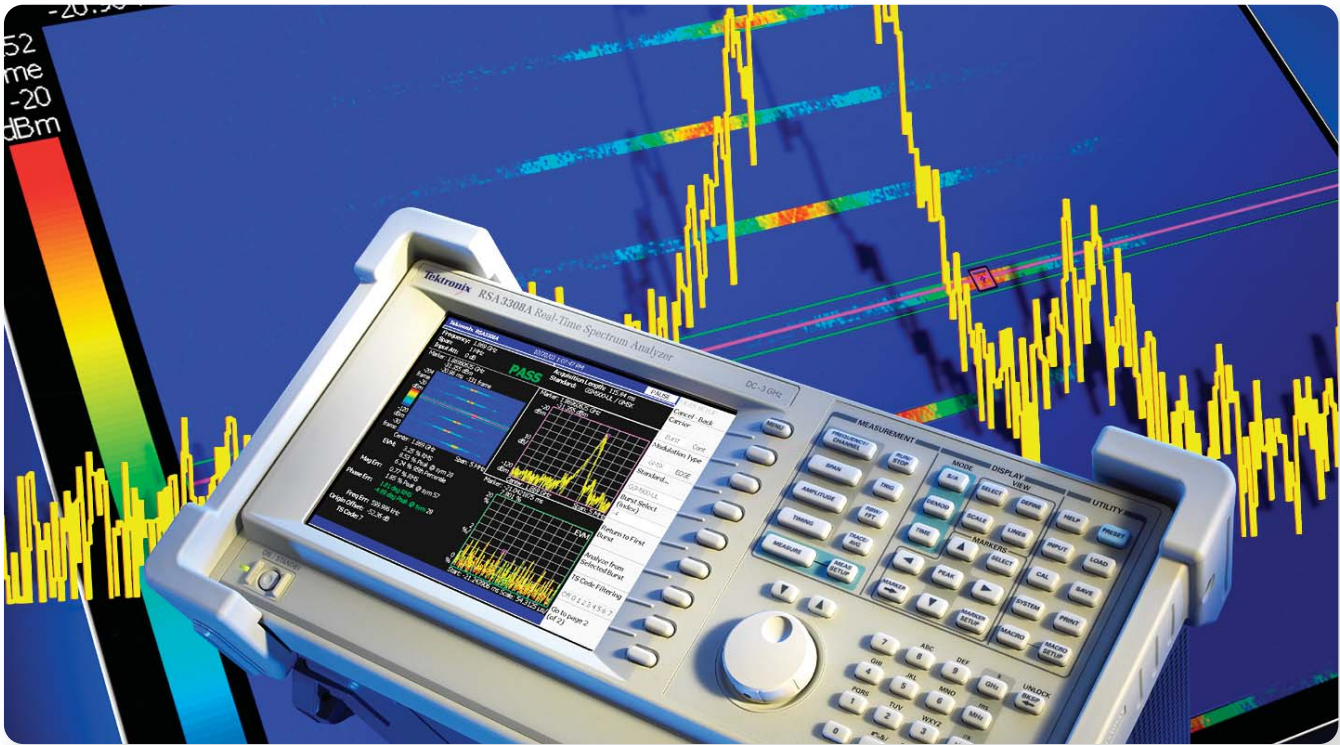

Real-time spectrum analysis is a technology whose relevance is stronger today than ever before. Due to the evolution of RF signals, real-time spectrum analysis has emerged as the vehicle for addressing new complexities found in RF applications such as RFID and spectrum monitoring.

The new generation of Tektronix Real-Time Spectrum Analyzers (RSA) utilizes real-time frequency analysis techniques to enable RF signal analysis not previously possible, even with swept-frequency spectrum analyzers and vector signal analyzers.

## Real-time versus swept-frequency

Conventional swept-frequency spectrum analyzers (SA's) have a single path from the input to the display that is

continuously tuned through the selected frequency range. Their displays represent the composite result of tuned acquisitions taken serially over a relatively long period, a valid approach only for stationary, uninterrupted signals. Signal components at frequencies other than the current sweep value are not detected, so swept analyzers are more likely to miss intermittent events than capture them – events that are critical factors in new generation systems.

# Real-Time Spectrum Analysis Overview

## ► Technical Brief

The basic swept spectrum analyzer architecture does not lend itself to capturing the details of a signal that is carrying digital modulation. The vector signal analyzer (VSA) emerged to address the distinctive requirements of digitally modulated signals. Unlike the swept SA, the VSA is optimized for modulation measurements. It captures the whole signal and any digital modulation effects occurring at one instant in time, providing fast readings of key modulation parameters such as Error Vector Magnitude (EVM). Since it is intended to complement a swept SA, the VSA's frequency-domain spectrum analysis features are not the equal of a standalone spectrum analyzer. Moreover, the VSA is not designed to trigger on, capture and analyze time-varying signals.

The real-time spectrum analyzer (RSA) has emerged to solve this tough measurement problem. Formerly limited to baseband applications, the RSA now addresses channelized signals across a broad RF range. Alone among the three spectrum analyzer architectures, the RSA can trigger on a frequency domain event, then capture and analyze any passband signal that falls within its real-time bandwidth.

Figure 1 depicts the RSA architecture. An integrated down-converter positions the real-time bandwidth on any passband up to the analyzer's upper limit. After filtering, the down-converted signal goes through an ADC that digitizes it, allowing triggering, capturing and analysis of the signal all at once.

Since the basic process is not one of sweeping across the RF input signal and building an image from serially acquired frequency steps, the RSA's digital IF architecture allows a continuous capture of "snapshots" known as frames. These frames accumulate in the memory as a seamless, continuous record of time. The memory supports a variety of display and analysis tools including the spectrogram, which plots an entire series of frames to reveal signal changes over time.

Thus, the RSA is the only RF signal analyzer that is optimized to produce a three-dimensional display: frequency, power (amplitude), and time.

If the passband of interest exceeds the real-time bandwidth of the RSA, it can step through a series of frequency segments, just like the swept analyzer. In doing so, each sweep captures a band of frequencies equivalent to the RSA's real-time bandwidth. Then the instrument concatenates the frequency bands and presents a conventional frequency-domain display.

Today's RSAs can trigger on changes in transient RFID signals in the time or frequency domain while seamlessly capturing and saving RF signals in the frequency range to be observed. They can also perform simultaneous frequency axis and time axis analysis and establish detailed correlations between the two.

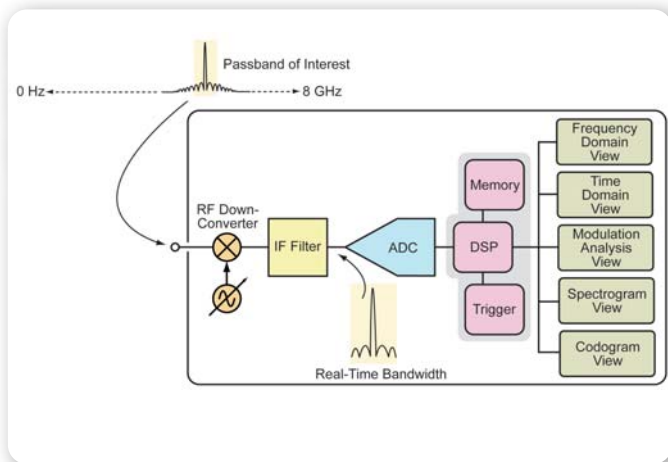

► **Figure 1.** Real-time spectrum analyzer architecture. The instrument captures a full passband of frequencies all at once, and the DSP supports flexible triggering and analysis features.



## Contact Tektronix

**ASEAN / Australasia / Pakistan** (65) 6356 3900  
**Austria** +43 2236 8092 262  
**Belgium** +32 (2) 715 89 70  
**Brazil & South America** 55 (11) 3741-8360  
**Canada** 1 (800) 661-5625  
**Central Europe & Greece** +43 2236 8092 301  
**Denmark** +45 44 850 700  
**Finland** +358 (9) 4783 400  
**France & North Africa** +33 (0) 1 69 86 80 34  
**Germany** +49 (221) 94 77 400  
**Hong Kong** (852) 2585-6688  
**India** (91) 80-22275577  
**Italy** +39 (02) 25086 1  
**Japan** 81 (3) 6714-3010  
**Mexico, Central America & Caribbean** 52 (55) 56666-333  
**The Netherlands** +31 (0) 23 569 5555  
**Norway** +47 22 07 07 00  
**People's Republic of China** 86 (10) 6235 1230  
**Poland** +48 (0) 22 521 53 40  
**Republic of Korea** 82 (2) 528-5299  
**Russia, CIS & The Baltics** +358 (9) 4783 400  
**South Africa** +27 11 254 8360  
**Spain** +34 (91) 372 6055  
**Sweden** +46 8 477 6503/4  
**Taiwan** 886 (2) 2722-9622  
**United Kingdom & Eire** +44 (0) 1344 392400  
**USA** 1 (800) 426-2200  
**USA (Export Sales)** 1 (503) 627-1916  
**For other areas contact Tektronix, Inc. at:** 1 (503) 627-7111

### For Further Information

Tektronix maintains a comprehensive, constantly expanding collection of application notes, technical briefs and other resources to help engineers working on the cutting edge of technology. Please visit [www.tektronix.com](http://www.tektronix.com)



Copyright © 2004, Tektronix, Inc. All rights reserved. Tektronix products are covered by U.S. and foreign patents, issued and pending. Information in this publication supersedes that in all previously published material. Specification and price change privileges reserved. TEKTRONIX and TEK are registered trademarks of Tektronix, Inc. All other trade names referenced are the service marks, trademarks or registered trademarks of their respective companies.

08/04 DM/WOW

37W-18054-0

**Tektronix**  
Enabling Innovation

