

## Measuring variable-speed motor drive output voltage with a Fluke ScopeMeter® 190 Series

### Application Note

Variable-speed motor drives, also known as “frequency inverters”, are spreading widely amongst industrial installations. During installation and service, measurements on the output voltages often give unexpected results. How is this possible, and what can be done to overcome this?

#### Variable-speed motor drives

Traditional electrical machinery connected directly to a single or three-phase power system have only a very limited range of speed control, if any at all. An external gearbox provides a solution but is bulky, noisy, expensive and subject to wear.

The availability of new semiconductor devices handling high voltages and large currents has opened the door for the design of so-called variable-speed motor drives or ‘frequency inverters’. These devices offer broad flexibility in speed control and match this to low electrical losses and a constant torque that can be independent of the actual rotational speed of the machine.

As a result, the use of variable-speed motor drives is spreading widely amongst industrial installations where they offer many advantages including:

- the elimination of wear, because asynchronous machines are used,
- effective control, and
- high energy efficiency.

During installation and service, however, measurements on the output voltages often give unexpected results. Here we explain how this is possible and what can be done to overcome it using Fluke 190 Series ScopeMeters.

#### Generating variable-frequency output

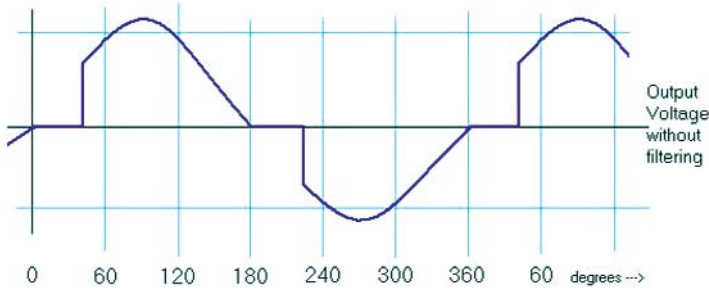
Several methods are available for generating the variable frequency output. The first designs were known as self-controlled or machine-synchronized thyristor power converters. These are still found today in high-power frequency inverters but for lower power applications better alternatives have become available.

Thyristors (Silicon Controlled Rectifiers or SCRs) can be turned off only at zero crossing of the mains current, which is why the output voltage of these converters isn’t a continuous sine wave but always shows discontinuities (for instance as seen in figure 1). Here, changing the phase angle of the discontinuity effectively controls the output power, which can be used to change the machine speed while reducing mechanical power available. Unfortunately, these converters don’t allow for random



modulation of the output waveform; attempts to resolve this using extra circuitry have proven to be expensive yet have met with only limited success.

Once so-called ‘gate-controlled turn-off power semiconductors’ became available, a totally different approach to variable-speed motor control became possible. Such semiconductors can be turned off as well as on, which makes them suitable for ‘chopping’ in a DC system. Figure 2 gives the basic structure of such drives.



**Figure 1:** Output voltage of SCR-based power converter. The unfiltered output voltage clearly shows discontinuities.

The single- or three-phase mains input is connected to a series of rectifiers that feed an internal DC bus. Here the DC voltage is buffered in a large-value storage capacitor, charged to a voltage  $U_b$ :

$$U_b = \sqrt{2} \cdot U_{\text{mains}} \approx 1.41 \cdot U_{\text{mains}}$$

The DC voltage is then applied to a series of double-sided switches that alternately connect each of the three machine connections to either the positive or the negative bus line. Furthermore, each branch of switches can be in the inactive (i.e. non-conductive) mode, effectively floating the machine connection to which it is connected.

The switches are all controlled by a central Control Unit that generates the driving pulses to activate each of the 6 switches at the proper instant. The switching speed can be varied and this determines the output frequency. The order in which the three outputs are driven determines the rotational direction of the machine.

The control unit is set up such that the output frequency can be varied over a broad range. And because the

machine's rotational speed depends directly on the frequency of the supply, the speed of the machine can effectively be controlled. Figure 3 gives the resulting output voltages for each of the output lines. On each of the machine connections we see a positive impulse, a period where the connection is left unpowered, then a negative impulse, followed by yet another period where no driving voltage is applied.

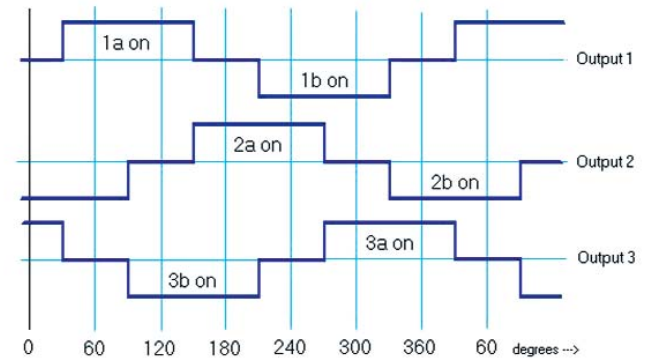
In this simple case, the open output voltage of each of the outputs is either  $+\frac{1}{2} U_b$  or zero (floating), or  $-\frac{1}{2} U_b$ , where  $U_b$  is the bus-voltage. Note that because all three outputs are connected the same way, the mean value for each of the output lines is at half the DC-bus voltage.

If we applied the above waveform to a low-pass filter, the output would resemble a sine wave with the same fundamental frequency as the square wave which is dictated by the control circuitry (see figure 4). However, low-pass filters that can handle the energy levels encountered in motor drives would be bulky and expensive, so alternatives for these have been developed.

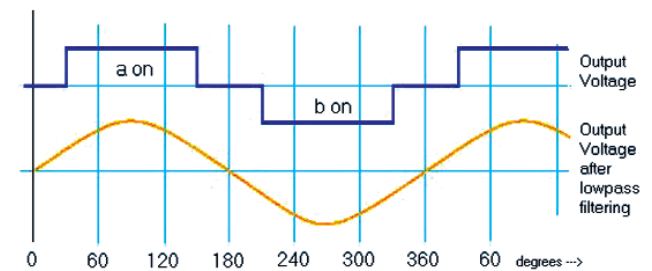
### Alternative to low-pass filtering

The alternative to low-pass filters has come from another improvement in power electronics. In real systems, the positive and negative pulses are generally not created by generating a single pulse of the desired polarity. Instead all pulses are generated by repeatedly switching on and off the same solid-state switch at a much higher pulse-rate using a varying on-off duty cycle (see figure 5).

The trick now is that the duty cycle is varied such that the current (but not the voltage) through the machine winding has a sine waveform. In effect, the induction of

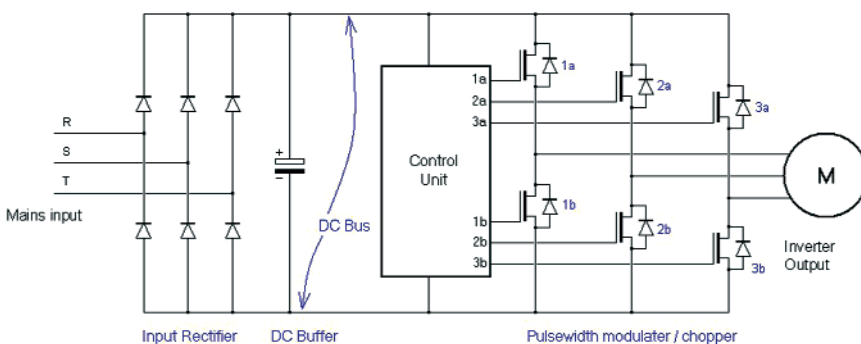


**Figure 3:** Output voltage for each of the individual output lines.



**Figure 4:** Output voltage directly and through a low-pass filter.

the machine windings then functions as the low-pass filter in which a current with a sine waveform flows as the result of a pulse-width modulated voltage.



**Figure 2:** Basic structure of a variable-speed motor drive.

In figure 5, the upper curve gives the output voltage for one output line only in which the effect of duty-cycle variation is clearly seen; the lower curve gives the effective output voltage per internal clock cycle T on a relative scale.

the electrical machinery, the voltmeter will respond to the unfiltered output voltage.

This is due to the voltage waveform as well as to the design characteristics of digital multimeters.

$$U_{\text{mean}} = d * U_{\text{peak}} = d * ( \frac{1}{2} U_b )$$

where: d = duty cycle, which changes from 0 to 100% and back.

The result is a meter reading in volts that may deviate significantly from the value expected on the machine terminals (as seen, for example, on a display incorporated in the motor drive itself that reads the effective output voltage calculated by the internal control electronics).

As an illustration of the above, we've tested a number of multimeters of different make and model, all under exactly the same conditions, using the same motor drive with the same settings.

The measured results, given in table 1, range from 143 V up to 1000 V!

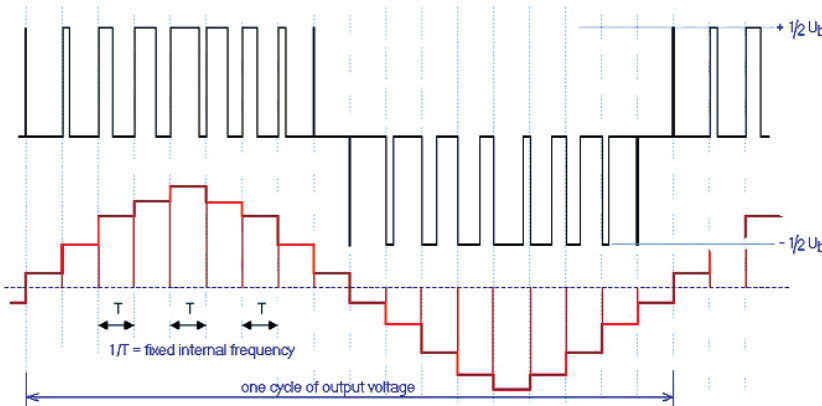


Figure 5: Output voltages for pulse-width-modulated motor drive (simplified).

This indicates that the effective output voltage has a sine waveform. However, the real output voltage of the motor drive resembles much more closely the upper curve! In contrast to the SCR circuits mentioned earlier, the drive circuitry can now be used in switched mode all the time, and therefore energy losses in the semiconductor switches are minimal, giving high energy efficiency and low heat generation in the drive module.

### Voltage measurements

Although the improvements in efficiency and the freedom in speed control with these motor drives are evident, there is a complication for the engineer responsible for installing or carrying out service work on these motor drives.

The output voltage of the motor drive is generated with the aim of producing a current with a sine waveform through an inductive load, but the applied voltage has a completely different waveform. Measuring the output voltage directly may therefore give unexpected results because, unlike

These are generally designed to measure the amplitude of a sine wave at mains frequency, i.e. 50 or 60 Hz. In contrast, the output voltage of the variable-speed drive is a square wave of high frequency, and its duty cycle changes continuously. On the other hand, the peak amplitude of the square wave is fixed. Finally there are two polarities to deal with!

Most multimeters are designed to respond to the peak-, peak-peak- or mean voltage applied, and these multimeters are then calibrated to read the effective amplitude of the sine wave. What's more, when used for AC-voltage measurements, most multimeters have a double-phase rectifier at the input to ensure that voltages of either polarity contribute equally to the reading.

If we look at the output voltage as shown in figure 5, the average voltage per cycle T (after rectification) is directly proportional to the duty cycle of the waveform and to the DC-bus voltage, and is therefore constantly changing because the duty cycle is varied. Within a half-cycle of the resulting current, the mean voltage will then be:

Digital multimeter model	Reading (Vac)
1	1001 V
2	154.2 V
3	157.6 V
4	170.1 V
5	187.1 V
6	193.6 V
7	204.3 V
8	215.3 V
9	237.93 V
10	254 V
Fluke 41B	143V
Fluke 43B	143.3 V
Fluke 190 Series	144 V

Table 1: – AC-voltage reading using various digital multimeters

### Making the right measurements

The proper way to calculate the output voltage for this particular situation is by taking into account the particular application of the motor drive.

The drive power for electrical machinery is derived from the current through the machine windings, whereas the applied

voltage is basically needed only to make that current flow. Variable-speed motor drives make use of this fact by applying a high-frequency, non-continuous voltage that results in a current with a sine waveform through the machine windings with a frequency governed by the control unit and the polarity of the switched voltage.

So if we want to know the effective output voltage of the motor drive, we should take into account only the fundamental frequency component of the applied voltage. This can be obtained by taking a large number of samples of the applied voltage and building a detailed image of the voltage waveform within the digital memory of the instrument, from which the amplitude of the fundamental frequency component can be calculated and displayed.

This is exactly what is done in the last three test-instruments listed in table 1. This includes the Fluke 190B and 190C Series ScopeMeters where all incoming voltages are digitized at a high sample rate and a digital image of the waveform is stored in memory for further analysis.

The 190 Series ScopeMeters are equipped with a dedicated voltage measurement function labelled "V<sub>pwm</sub>-measurement" targeting these applications. With this function, the 190 Series ScopeMeters can analyze the digitized signal and calculate the fundamental frequency. This will have the same waveform as the motor drive's output current. From this waveform, the effective value is then calculated and displayed as the V<sub>pwm</sub>-reading.

See the screen copy in figure 6, where both the peak-to-peak amplitude and the effective output voltage of a motor drive are given in small boxes at the top of the screen.

The effective output frequency of the displayed waveform can easily be determined here: a single cycle takes approximately 6.3 divisions, the timebase setting is 5 ms, so a single cycle takes approximately 31.5 ms. The output frequency is then  $1 / 31.5 \text{ ms} = 32 \text{ Hz}$ .

Alternatively, the cursors may be used to mark a cycle of this output waveform.

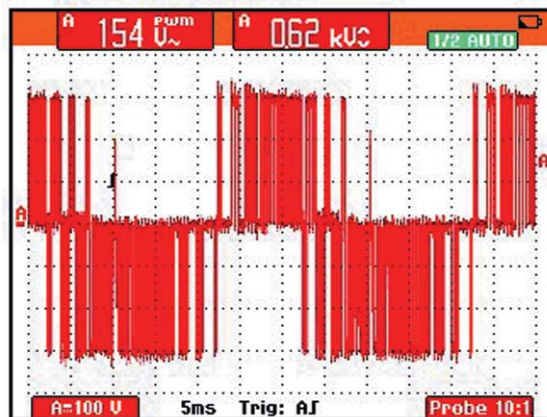


Figure 6: Motor drive output measured using the Fluke 199C

## Conclusion

Variable speed motor drives bring a lot of advantages to the machine builder and user.

For the service engineer and the installer of the machine drives, a complication is in measuring the output voltages of the drives. Only test equipment that is specifically prepared for testing these output voltages will give reliable readings, in line with the (calculated) reading on the motor drive itself.

The Fluke 190 Series ScopeMeter is

particularly well suited for use during installation and service on these variable speed motor drives, and is equipped with all test functions you may need.

**Fluke.** Keeping your world up and running.

**Fluke Corporation**  
PO Box 9090, Everett, WA USA 98206

**Fluke Europe B.V.**  
PO Box 1186, 5602 BD  
Eindhoven, The Netherlands

**For more information call:**  
In the U.S.A. (800) 443-5853 or  
Fax (425) 446-5116  
In Europe/M-East/Africa (31 40) 2 675 200 or  
Fax (31 40) 2 675 222  
In Canada (800)-36-FLUKE or  
Fax (905) 890-6866  
From other countries +1 (425) 446-5500 or  
Fax +1 (425) 446-5116  
Web access: <http://www.fluke.com>