

CAPACITOR LEAKAGE CURRENT/IR METER

MODEL 11200

Key Features :

- Capacitor leakage current test function
- Insulation Resistance (IR) test function
- Basic accuracy : 0.3%
- Aluminum-foil withstand voltage and rise-time test function. (For EIAJ RC-2364A)
- 1~650V, 150mA/500mA or 1~800V, 50mA/500mA low noise DC voltage source
- Precision low constant current charge capability (0.5mA \pm 0.05mA, meets EIAJ RC-2364A requirement for withstand voltage testing of lower WV aluminum-foil)
- Large charge current (500mA) capability to fasten charge speed
- 0.001 μ A ~ 20.00mA leakage current test range with 4 digits resolution
- 65W semi-constant power discharge circuit
- Built-in RS232 interface
- Optional GPIB & Handler interface
- Digital timer inside
- Comparator and Pass/Fail alarming beeper function
- Large LCD display (240 x 64 dot-matrix)
- Friendly user interface

Application :

- For leakage current testing or insulation resistance testing of various electrolytic capacitors, high dielectric ceramic capacitor etc..
- For aluminum-foil withstand voltage testing (for EIAJ RC-2364A)
- For semiconductor component leakage current testing or insulation resistance testing
- For insulation resistance testing of various anti-static electric materials or non-ultra-high insulation materials (IR<100G Ω)



CAPACITOR LEAKAGE CURRENT/IR METER MODEL 11200

The Chroma 11200 Capacitor Leakage Current / IR Meter is Chroma's newest digital leakage current meter. Provides DC 1-650 V, 0.5mA~500mA (150mA for V > 100V) or DC 1~800V, 0.5mA~500mA (50mA for V > 100V) DC power source with voltage meter and nano-ampere meter. Mainly used for electrolytic capacitor leakage current testing, and aluminum-foil withstand voltage testing (EIAJ RC-2364A). And also can be used for active voltage checking or leakage current testing of absorber, Zener diode, and Neon lamp etc. Standard RS232 interface, optional GPIB & Handler interface, high speed and stable measurement capabilities enable the Chroma 11200 can be used for both component evaluation on the production line and fundamental leakage current or IR testing for bench-top applications.

1~650V, 150mA/500mA or 1~800V, 50mA/500mA Low Noise DC Voltage Source

A low noise linear power supply is designed in the Chroma 11200. The DC output voltage range is from 1.0V to 650V/800V, which covers low WV capacitor leakage current testing and aluminum-foil withstand voltage testing range. The maximum charge current is 500mA/ 100V, 150mA / 650V or 50mA / 800V, provides quick charge for large capacitor testing.

Precision low constant current charge capability (0.5mA \pm 0.05mA)

In general, the aluminum electrolytic capacitor's anode oxide-foil is using extremely low constant current (EIAJ-RC2364A's standard is 0.5mA, 1mA or 2mA \pm 10%; depends on the type of the foil) to test foil withstand voltage (Vt) and rise time (Tr) etc.. The Chroma 11200 provides constant charge current low to 0.5mA with high stability.

0.001 μ ~20.00mA Leakage Current Test Range With 4 Digits Resolution

A 0.001 μ A to 20mA test range nano-ampere meter is built in the Chroma 11200. It is proper to be used for leakage current or IR testing of electrolytic capacitor and high dielectric ceramic capacitors. And the extremely low input resistance (the lowest is 0 ohm) design enables high speed testing for high capacitance device LC or IR testing.

Output Voltage Monitor

The Chroma 11200 always keeps monitoring the real output voltage no matter in the test or setup operation status for safety of the operator. In addition to display the real output voltage in TEST page, an error message shows-up in case of the output voltage is abnormally exceeds 10 volts in other operation pages.

65W/50W Semi-constant Power Discharge Circuit

A 65W semi-constant power discharge circuit is built in the Chroma 11200 for high speed and completely discharge after test. It satisfies quick discharge requirement for charged large capacitors.

Built-in RS232 Interface, and Optional GPIB & Handler Interface

The Chroma 11200 built-in RS-232 interface can be used in R&D or QC for remote control and tested data fetch. And, GPIB and HANDLER interface (A110235) is optional for automation..



Chroma

APPLICATIONS

Standard Leakage Current Testing for Various Electrolytic Capacitors

Capacitor leakage current is defined in standards. In general, the leakage current is after charged (the Chroma 11200 is using 98% for identity) plus a period time (for example 60 sec. ± 10 sec.). And, the Chroma 11200 provides a semi-constant-power discharge circuit for quick discharge after testing. Therefore, selecting [SEquence] test mode for this application is recommended. It will follow the preset time to charge, test and then discharge. After that, it will display the tested result and judge Pass/Fail.

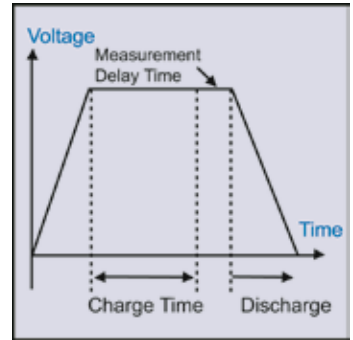
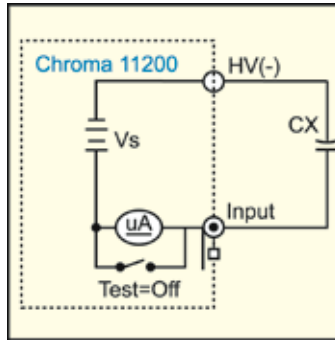

Automatic Production Test for Various Electrolytic Capacitors

On the automatic production line of electrolytic capacitors, generally, several pre-charging stations are built with a current limit series resistor in each station. When set the meter in [STEP] test mode, TEST status, measure the Leakage Current via an external trigger. The Chroma 11200 provides up to 500mA (below 100 volts) large output current and low noise voltage source which can be used as charging and testing voltage source. The tested result will be displayed includes Pass/ Fail judge. In addition, it can be controlled through the GPIB interface and Handler interface for automation.

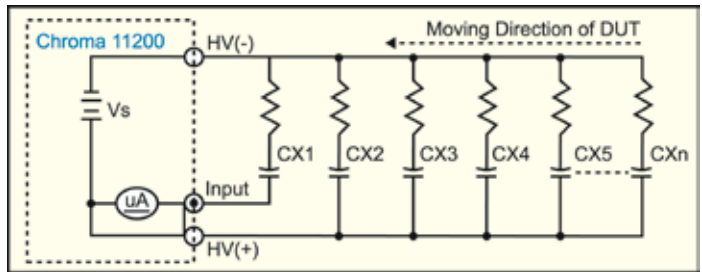

Aluminum-foil Withstand Voltage Testing

Generally, the withstand voltage (V_t) and the rise time (T_r) testing of aluminum oxide foil follows EIAJ-RC2364A standard, to drive a constant current (0.5mA, 1mA or 2mA; depends on the type of the foil) to test. In general, the test system is expensive because the needed constant charge current is very low, and the permitted tolerance of the current is very small (± 0.05 mA), and needs a high speed voltage sampling with a built-in timer. The Chroma 11200 provides WV (withstand voltage) test function for complete solution. And 220 points of tested WV curve data can be fetch via built-in RS232 interface.

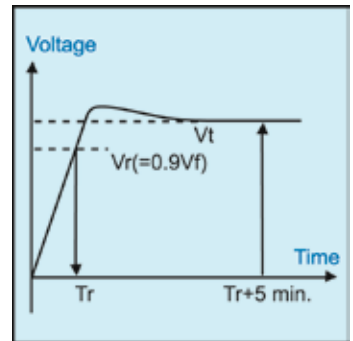
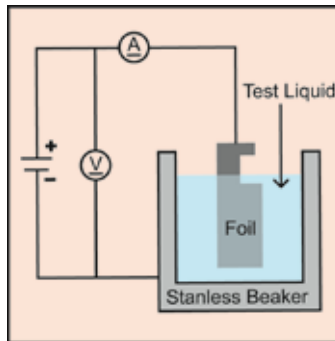

Low Capacitance Device Leakage Current or IR Testing

In leakage current or IR testing of low capacitance device, because the charge time needed is shorter, normally the charge process can be skipped. Select [STEP] test mode, TEST status for direct testing is recommended. "INTernal" trigger is proper to be selected for quality check, and "EXTernal" trigger is proper to be selected for automatic production test.

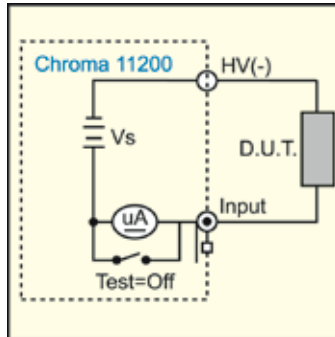

DIGITAL FUNCTION

Null

Eliminates the measurement error caused by leakage current of outside test jigs and offset voltage of inside circuit.

Compare

Selection of comparator function ON and OFF. The limit can be set to single Upper or Lower, and both, depends on test requirement. For example, for general insulation material and capacitor, lower than the upper limit of leakage current is Pass. However, for anti-static electric materials, upper than the lower limit of leakage current or between the upper and lower limits is pass.

SOFT PANEL

Chroma 11200 Soft-Panel provide control function for three test (Leakage Current / IR Test, Null Test and Withstand Voltage Test) and system configuration. User set detail condition for test and control Chroma 11200 test step through soft-panel. It also has report function, that soft-panel outputs a test result included a curve to a printer or save it to a Excel file. Customer use the excel file for more application, like calculate capacity with set constant current and time and voltage measurement data at withstand voltage test ($C = I \cdot dt / dV$).



TEST MODES

● SEQ. Test Mode

Provides sequence test of charge, test, and discharge by a single trigger. Setup conditions :

• Charge Time

There are two ways of identity of charge time. One is start to count after full charged ($V_m = V_s$). Another is start to count from the beginning ($V_m = 0$). Most of standards require the first one.

• DWELL Time

After switching from charging to LC measuring while testing, an RC (meter output resistance and unknown capacitance) delay time is needed for accurate measurement. Input resistance of each current test range, please refer to the operation manual for detail.

• Test sampling SPEED

• TEST Voltage

• Charge constant Current (C.C)

• Leakage current test range (RANGE)

For automatic testing or Pass/Fail check, range-held is recommended to fasten the test.

● STEP TEST Mode

The steps of Charge, measurement, discharge is controls by manual. Setup conditions:

• TEST Voltage

• Charge constant current (C.C)

• Leakage current test RANGE

• TRIGGER mode

• Test sampling SPEED

● Aluminum-foil Withstand Voltage (WV) test mode

For aluminum-foil withstand voltage (V_t) and rise time (T_r) testing. Setup conditions:

• Aluminum-foil rated withstand voltage (V_f)

• Charge constant Current (C.C)

Aluminum-foil withstand voltage testing current. (EIAJ RC-2364A: extremely low WV foil→0.5mA, low WV foil→1.0mA, middle and high WV foil→2mA)

• Withstand voltage identity time (T_{end})

The aluminum-foil withstand voltage identity time after the rise time (T_r , the time which voltage reached 90% V_f). (EIAJ RC-2364A: 5min.).

• Charge Tend

If the charge voltage could not reach 90% of V_f during this setting time because of excess leakage current or large capacitance, the test will be terminated any the final charged voltage will be showed as the tested result.

SYSTEM CONFIG

TEST PARAMETER

There are two main test parameters, leakage current (L.C.) and insulation resistance (I.R.).

BEEPER

It's a beeper volume selection. The Chroma 11200 beeps for Pass/Fail judge and key-pressed echo.

SOUND MODE

It's a selection of beeper sound output for Pass/Fail judge. The Chroma 11200 provides CONTINUOUS and PULSE selections.

ALARM MODE

A selection of Pass or Fail alarm

TRIG. DELAY

Delay time is between the test start and the external trigger. Generally used for automatic equipment timing adjustment or delay time for waiting a real leakage current.

TRIG. EDGE

The Chroma 11200 provides RISING and FALLING edge trigger selections for automation.

HANDLER MODE

There are two selections of Handler I/O output result during the test period. One is HOLD mode, the output signal (PASS or FAIL) of tested result will remain until the next test result comes otherwise. Another is CLEAR mode, force the output signals to FAIL indications until the next test result comes otherwise.

CONTRAST

LCD contrast adjustment

GPIB ADDRESS

From 00 to 30

RS232 BAUDRATE

It's RS232 transmission baud rate selection. There are 600,1200,4800,9600,19200 and 28800 for selecting.

KEY LOCK

The Key Lock function is designed to avoid the setup information is changed and the keypad is touched by mistake.

LINE FREQUENCY

The measurement of micro current is easily interfered by power noise. The Chroma 11200 used advanced power noise filtering technology to filter the selected line frequency noise accordingly for accurate measurement.

CHARGE TIME

Refer to the description in TEST MODES – SEQUECE TEST.

RANGE DWELL

Provide the delay time for changing range. During the range changing, an RC (meter output resistance and unknown capacitance) delay will affect the tested result. A delay time is necessary for accurate measurement. Refer to the operation manual for detail.

Average

Setting of the average number of tested value

EXT VM DISPLAY

For fasten test speed at automatic production test, output voltage monitor function can be selected to off. The Chroma 11200 will keep displaying the initial charged voltage.

SPECIFICATIONS

Model	11200 (650V)	11200 (800V)
Main Function	Capacitor Leakage Current / IR Meter	
Test Parameter	LC, IR	
Test Signals Information		
Voltage	1.0~100V, step 0.1V; 101V~650V, step 1V, $\pm(0.5\%+0.2V)$	1.0~100V, step 0.1V; 101V~800V, step 1V, $\pm(0.5\%+0.2V)$
Charge Current Limit	$V \leq 100V: 0.5mA \sim 500mA$; $V > 100V: 0.5mA \sim 150mA, 65W \text{ max}$ step 0.5mA; $\pm(3\%+0.05mA)$	$V \leq 100V: 0.5mA \sim 500mA, 50W \text{ max}$; $V > 100V: 0.5mA \sim 50mA, 40W \text{ max}$ step 0.5mA; $\pm(3\%+0.05mA)$
Measurement Display Range	LC: 0.001 μ A~20.00mA	
Basic Measurement Accuracy (Note)	LC Reading: $\pm(0.3\% \text{ of reading} + 0.005\mu A)$	
Measurement Speed (Ext. Trigger)		
Fast	50mS	
Medium	70mS	
Slow	130mS	
Function		
Correction	Null Zeroing	
Test Voltage Monitor	$V_m: 0.0V \sim 660.0V; \pm(0.2\% \text{ of reading} + 0.1V)$	$V_m: 0.0V \sim 900.0V; \pm(0.2\% \text{ of reading} + 0.1V)$
Charge Timer	0~999 Sec	
Dwell Timer	0.2~999 Sec	
Foil WV Tester		
Test Parameter	Tr (Rise Time), Vt (Foil Withstand Voltage)	
Test Signals		
Voltage Limit	650V Typical	800V typical
Constant Charge Current	0.5mA~150mA, step 0.5mA; $\pm(3\% \text{ of reading} + 0.05mA)$	0.5mA~50mA, step 0.5mA; $\pm(3\% \text{ of reading} + 0.05mA)$
Test Display Range		
Tr(Rise Time)	0.05 ~ 600.00 Sec	
Charge Voltage	0.1V ~ 660.0V	0.1V ~ 900.0V
Test Time	30 ~ 600Sec	
Interface	RS-232 (Standard), Handler, GPIB (Optional)	
Display	240 x 64 dot-matrix LCD display	
Trigger	Internal, External, Manual, Bus	
General		
Operation Environment	Temperature : 10°C ~ 40°C; Humidity : < 90%RH	
Power Consumption	400 VA max	
Power Requirement	95 ~ 125Vac or 190 ~ 250Vac ; 48Hz~62Hz	
Weight	Approx. 10Kg	
Size (WxHxD)mm	320 x 115 x 350 mm	

Note: 23 \pm 5°C after Null correction. Refer to Operation Manual for detail measurement accuracy descriptions.

PANEL DESCRIPTION

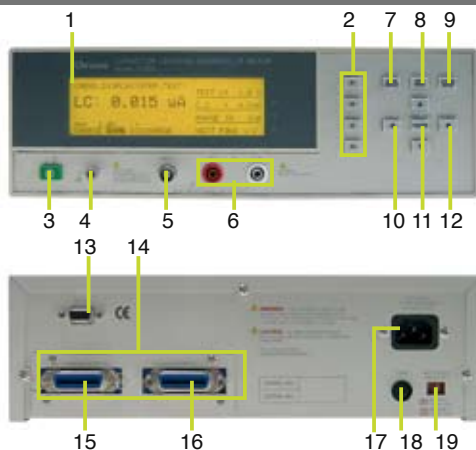

1. LCD Display
2. Function Keys
3. Power Switch
4. Ground Terminal
5. Current Input Terminal
6. Voltage Output Terminals
7. MEAS DISPLAY Key
8. MAIN INDEX Key
9. SYSTEM SETUP Key
10. Cursor Keys
11. Trigger/Charge/Test Key
12. Right Cursor/Discharge Key

13. RS232 Interface
14. GPIB and Handler Interface (A110235Option)
15. HANDLER Interface
16. IEEE-488 Interface
17. AC Line Input
18. Fuse
19. Line Voltage Selector

ORDERING INFORMATION

- 11200** Capacitor Leakage Current / IR Meter 650 V
11200 Capacitor Leakage Current / IR Meter 800 V
A112004 Softpanel
A110235 GPIB & Handler Interface

Developed and Manufactured by :

CHROMA ATE INC.
 致茂電子股份有限公司
HEADQUARTERS
 66 Hwaya 1st Rd., Kueishan
 Hwaya Technology Park,
 Taoyuan County 33383,
 Taiwan
 Tel: +886-3-327-9999
 Fax: +886-3-327-8898
<http://www.chromaate.com>
 E-mail: info@chromaate.com

CHINA
CHROMA ELECTRONICS
(SHENZHEN) CO., LTD.
 8F, No.4, Nanyou Tian An
 Industrial Estate, Shenzhen,
 China PC: 518052
 Tel: +86-755-2664-4598
 Fax: +86-755-2641-9620

JAPAN
CHROMA JAPAN CORP.
 472 Nippa-cho, Kouhoku-ku,
 Yokohama-shi, Kanagawa,
 223-0057 Japan
 Tel: +81-45-542-1118
 Fax: +81-45-542-1080
<http://www.chroma.co.jp>
 E-mail: info@chromaate.com

U.S.A.
CHROMA SYSTEMS
SOLUTIONS, INC.
 19772 Pauling, Foothill Ranch,
 CA 92610
 Tel: +1-949-600-6400
 Fax: +1-949-600-6401
<http://www.chromausa.com>
 E-mail: sales@chromausa.com

EUROPE
CHROMA ATE EUROPE B.V.
 Morsestraat 32, 6716 AH Ede,
 The Netherlands
 Tel: +31-318-648282
 Fax: +31-318-648288
<http://www.chroma.eu.com>
 E-mail: sales@chromaeu.com

Worldwide Distribution and
 Service Network